



Prospectus for Grantors,
Exhibitors and Advertisers

June 4-6,
2006

Omni Shoreham Hotel
Washington, DC

FOR INFORMATION ON EXHIBITING,
SPONSORSHIPS AND ADVERTISING:

www.MedicaidCongress.com
800-546-3750

THE National Medicaid Congress

Strategies for Navigating the New Medicaid

Access national decision makers who will attend the National Medicaid Congress to learn critical information about emerging Medicaid reform models, the expanded role of Medicaid managed care, new federal and state strategies to manage costs, the impact of the Medicare prescription drug benefit, and the future of Medicaid long-term care.

Exhibitor Information

**Empire Ballroom
Omni Shoreham Hotel**

**June 4–6, 2006
Washington, DC**

Exhibit Management Contact:

Joni Lipson
100 North 20th Street, 4th Floor
Philadelphia, PA 19103

800-546-3750 (toll-free)
215-599-6626 (direct line)
Fax 215-545-8107
Email: Joni.lipson@rmpinc.com

Service Contractor Contacts:

Freeman Decorating
301-918-7900
www.myfreemanonline.com

Set-up/Teardown Hours:

SUNDAY, JUNE 4, 2006
3:00 pm – 6:00 pm Exhibitor Move-In

TUESDAY, JUNE 6, 2006
1:30 pm – 4:00 pm Exhibitor Move-Out

Viewing Hours:

MONDAY, JUNE 5, 2006
7:00 am – 5:30 pm

TUESDAY, JUNE 6, 2006
7:00 am – 1:00 pm

Events in the Exhibit Hall:

MONDAY, JUNE 5, 2006
7:00 am – 8:00 am Continental Breakfast
10:30 am – 11:00 am Break
12:15 pm – 1:15 pm Networking Luncheon
4:30 pm – 5:30 pm Networking Reception

TUESDAY, JUNE 6, 2006
7:00 am – 8:00 am Continental Breakfast
10:30 am – 11:00 am Break
12:15 pm – 1:15 pm Networking Luncheon

State Medicaid programs are undergoing fundamental transition. States are reshaping their Medicaid programs and their entire health systems by developing new models of providing benefits. The federal government continues to place Medicaid reform at the top of its agenda as it seeks broader cost savings. With the advent of the new Medicare prescription drug benefit, states must maneuver real-time challenges in managing their beneficiaries' health, while adjusting to the benefit's new financial requirements for states. These changes affect all health care stakeholders who must develop new policy and commercial strategies in response to the new evolution in Medicaid.

Access national decision makers who will attend the National Medicaid Congress to learn critical information about emerging Medicaid reform models, the expanded role of Medicaid managed care, new federal and state strategies to manage costs, the impact of the Medicare prescription drug benefit, and the future of Medicaid long-term care.

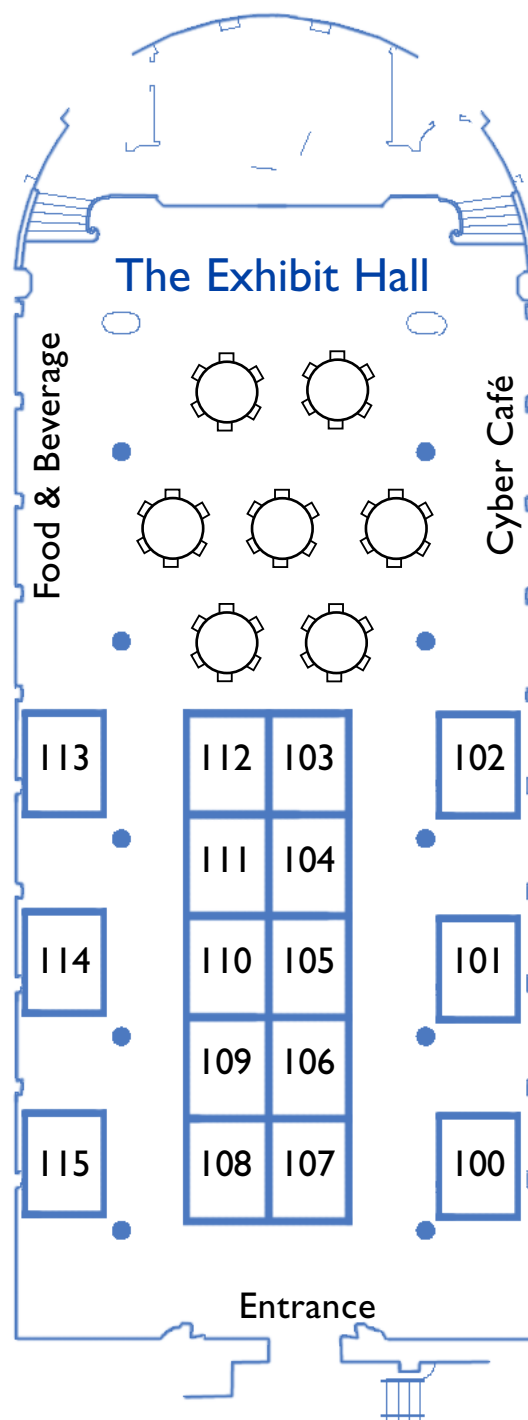

Promotional Opportunities

- Educational Grantor
- Sponsor
- Advertiser

Choose one of the above categories or combine two. Take advantage of this unique opportunity to expand your reach! The Medicaid Congress is attended by highly influential and experienced professionals. Sponsorship offers you strategic positioning as an industry leader. It produces positive results!

RECOGNITION

Each sponsor/grantor will be given a complimentary 75-word listing in the conference program. Please email a product and/or organization description to Joni Lipson, Conference Coordinator at Joni.lipson@rmpinc.com. Include contact name, phone number and website address.

CONFERENCE EVENTS

The conference programs and events will be structured to encourage maximum attendance. Events include the networking reception, breaks and daily continental breakfasts.

GRANTOR AND SPONSOR OPPORTUNITIES

The Congress provides opportunities for additional exposure through a variety of conference sponsorships. Following is a description of a few promotional opportunities.

NOTEPAD FOLIO

Your company name, logo and a small message would be displayed on the front cover of this notepad folio. Perfect for taking and organizing notes for the day. 3-ring binder included. \$25,000

NETWORKING RECEPTION

The networking reception will be held to include all conference attendees, exhibitors and food—a combination for success! \$15,000

CONFERENCE BAGS

These handsome canvas bags would be imprinted with your company name and logo and carried by all conference attendees. \$10,000

BADGE-HOLDER NECKLACES

Every registrant would wear your name, website and phone number around their neck. \$7,500

LUNCHEON

Host a luncheon in the Exhibit Hall. Benefits include public recognition during the luncheon. Signage recognizing your organization placed at the entrance to the Exhibit Hall. \$6,500

CYBER CAFE

Your company's banner displayed on screensaver of every monitor in the cyber cafe. Attendees will appreciate your sponsorship when they check their e-mail! Your company's logo and link will be posted on the Medicaid Congress home-page as the sponsor. \$5,000

CONFERENCE BINDER

With your company logo ad displayed on the back cover, and by the table of contents, these quality binders will be distributed free to all attendees. Likely to be used as a reference long after the Congress ends. Great exposure! \$5,000

POCKET SCHEDULE

Your company name, logo and a small message would be displayed on the back cover of our pocket schedule. It's a convenient way for attendees to review the agenda as they hurry to the next session. \$5,000

CONTINENTAL BREAKFAST

Host a continental breakfast in the Exhibit Hall. Benefits include public recognition during the breakfast. Signage recognizing your organization placed at the entrance to the Exhibit Hall. \$4,500

REFRESHMENT BREAK

Your company name would be displayed throughout the break. Attendees appreciate this energy boost! \$3,500

GEL CLICK PENS

Gel Click Pens imprinted with your company name/logo will be given to all attendees. \$2,500 (Sponsorship Fee)

CALCULATORS

Calculators imprinted with your company name/logo will be given to all attendees. \$3,500 (Sponsorship Fee)

COFFEE MUGS

Your selection of coffee mugs imprinted with your company name/logo will be placed at the break stations. \$2,500 (Sponsorship Fee)

Educational Grantors – Categories and Benefits

All Grantors Receive:

- Complimentary registrations
- Acknowledgement on a large screen multi-media presentation at the general sessions
- Booth in a choice location
- A large sign posted at the sponsored event
- Recognition in conference program binder
- Post-conference registration list

. . . *Plus:*

Diamond Grantor - \$100,000

- Recognition on cover of Medicaid Congress program binder
- Recognition on placards and overheads at the Medicaid Congress
- Full-page four-color advertisement or corporate profile in conference binder
- 20 Complimentary registrations to the Medicaid Congress
- Preferred grantor opportunities at the next Medicaid Congress
- Corporate profile with logo in Medicaid Congress binder
- Choose one event or item sponsorship, \$10,000 or less in value to sponsor at no additional cost
- First Diamond Grantor has right to hold invitation-only faculty dinner

Platinum Grantor - \$75,000

- Recognition on cover of Medicaid Congress program binder
- Recognition on placards and overheads at the Medicaid Congress
- Full-page black and white advertisement or corporate profile in conference binder
- 15 Complimentary registrations to the Medicaid Congress
- Preferred grantor opportunities at the next Medicaid Congress
- Corporate profile with logo in Medicaid Congress binder
- Choose one event or item sponsorship, \$8,000 or less in value to sponsor at no additional cost

Gold Grantor - \$50,000

- Recognition on cover of Medicaid Congress program binder
- Corporate profile with logo in Medicaid Congress binder
- 10 Complimentary registrations to the Medicaid Congress
- Priority grantor opportunities at the next Medicaid Congress
- Choose one event or item sponsorship, \$5,000 or less in value to sponsor at no additional cost

Silver Grantor - \$25,000

- Recognition on cover of Medicaid Congress program binder
- Brief corporate profile with logo in Medicaid Congress binder
- 5 Complimentary registrations to the Medicaid Congress
- Grantor opportunities at the next Medicaid Congress

Bronze Grantor - \$12,500

- Recognition on cover of Medicaid Congress program binder
- Brief corporate profile with logo in Medicaid Congress binder
- 2 Complimentary registrations to the Medicaid Congress
- Grantor opportunities at the next Medicaid Congress

Guidelines for Electronic File Output

File Types Accepted - Mac or PC:
Illustrator, Photoshop, PageMaker,
Freehand, QuarkXPress
No Word documents please.

Media Accepted:

Jaz, Zip, CD ROM, Floppy
If sending by e-mail please use Stuffit
to compress the files.
Please e-mail files to Joni Lipson at
Joni.lipson@rmpinc.com

Please Send:

- A printed directory of what is contained on the disk.
- All necessary proofs (see other information on this page).
- All individually placed artwork (EPS, TIFF etc.). Do not embed the graphics into the file.

General Information:

- We cannot edit text once it has been converted to paths.
- Scanned images for color and greyscale must be 300 dpi at 100%.
- Do not increase the image size in the application as this will decrease the resolution.
- Scanned line art and type must be 1200 dpi at 100%.
- Scans should be saved to disk as EPS or TIFF files. Be sure to convert scanned color images to CMYK before saving to disk; RGB is not acceptable. Use greyscale TIFFs for B&W halftones and bitmap for black line art.
- No PICTs, JPEGs or GIFs.

Increase your Visibility and Connect with Every Congress Attendee!

Advertising space in the official conference binder will provide you with invaluable exposure before the entire meeting attendance. Every guest will receive a binder with handouts. They will refer to it frequently. Many will even keep it as a handy reference volume. Each time these powerful decision makers page through this official publication they will see your ad and remember your product!

Ad Unit	Dimensions	Price
full page four color	7" x 10"	\$2,100
full page black/white	7" x 10"	\$ 800

Door Drops and Tote Bag Inserts available for grantors and exhibitors.

Company to provide their own marketing piece.

Please call for a price quote.

Reproduction Requirements

Printed Offset

NO Bleeds

Line screen is 150-175

Preferred materials: negatives, right-reading, emulsion side down. All reproduction materials must have register marks, center marks, and trim marks. Each negative must be marked for color.

COLOR ADS must be accompanied by 2 sets of progressive proofs and 2 final proofs or Chromalin proofs.

Color rotation is Magenta, Yellow, Black, Cyan.

We can accept ELECTRONIC FILES on disk or by e-mail. Files must be accompanied by laser proofs, or color proofs as specified above. Please see guidelines in the column at left.

Disposition of Materials

Materials will be held one year from last insertion and then destroyed unless we are specifically instructed otherwise.

Deadline for Materials

Artwork must be received by May 8, 2006.

Terms and Conditions

1. **EXHIBIT BOOTH** - Booths are standard 8' x 10' with flameproof side and back drapes, aluminum supports and waste basket. Each exhibitor will be provided a 6' skirted table and chairs and a 7" x 44" identification sign. This area is carpeted.
2. **RATES AND ASSIGNMENTS** - Assignments will be made on a first come, first serve basis. Each booth space includes two exhibitor personnel. Cost is \$1,995 per booth space.
3. **PAYMENT** - 100% payment is required for each booth space ordered. Payment may be made by check, Visa, MasterCard or American Express. Make check payable to Health Care Conference Administrators.
4. **EXHIBIT LOCATION AND FLOOR PLAN** - Exhibits will be located as indicated on the official floor plan. The exhibit management reserves the right to make modifications as necessary.
5. **FAILURE TO OCCUPY** - Space not occupied by the close of installation (unless previous written arrangements were made) will be forfeited by the Exhibitor. The Medicaid Congress may resell, reassign or use the space. If display equipment is available, the Congress may choose to have the exhibit erected at the Exhibitors expense.
6. **SET-UP/VIEWING/TEARDOWN HOURS:**
SET-UP HOURS:
Sunday, June 4, 2006, 3:00 pm – 6:00 pm
TEARDOWN HOURS:
Tuesday, June 6, 2006, 1:30 pm – 4:00 pm

VIEWING HOURS:
Monday, June 5, 2006,
7:00 am – 5:30 pm
Tuesday, June 6, 2006,
7:00 am – 1:00 pm

EVENTS IN THE EXHIBIT HALL:
Monday, June 5, 2006,
7:00 am – 8:00 am Continental Breakfast
10:30 am – 11:00 am Break
12:15 pm – 1:15 pm Networking Luncheon
4:30 pm – 5:30 pm Networking Reception

Tuesday, June 6, 2006,
7:00 am – 8:00 am Continental Breakfast
10:30 am – 11:00 am Break
12:15 pm – 1:15 pm Networking Luncheon
7. **CANCELLATION OF EXHIBIT CONTRACT** - The Medicaid Congress must be notified of exhibitor cancellation in writing. A cancellation fee of \$500 per booth will be charged to an exhibitor who cancels their contract before 5/8/06. No refunds will be made after this date.
8. **BADGES** - Each booth space will be furnished 2 badges, including one all-access badge. Additional all-access badges may be purchase at the standard registration rate. All exhibitor personnel must register and wear their badges for admission to the exhibit hall, special meals and included social events.
9. **CONFLICTING MEETINGS AND SOCIAL EVENTS** - In the interest of the entire conference, Exhibitor agrees not to extend invitations, call meetings, or schedule social events involving attendees, or otherwise encourage absence of members, other exhibitors, or invited guests at any time during dates of the event, without permission from the conference organizers.
10. **GENERAL SERVICES CONTRACTOR** - Freeman will serve as the general services contractor for the conference and will forward an exhibitor kit regarding other equipment availability, information, and shipping. Phone 301-918-7900.
11. **DRAYAGE** - Freight charges and shipping locations will be included in your Exhibitor Services Kits. This will be mailed approximately 6 – 8 weeks prior to the conference.
12. **INSTALLATION AND DISMANTLING OF EXHIBITS** - Set up for the exhibit will be Sunday, June 4, 2006 from 3:00 pm - 6:00 pm. All exhibits must be in place and ready for display by Monday, June 5, 2006 at 7:00am. Dismantling of Exhibits may begin at 1:30 pm on Tuesday, June 6, 2006. Setting up, tearing down and removal of exhibits are the responsibility of the Exhibitor. Should the Exhibitor fail to remove the exhibit, removal will be arranged by the conference management at the Exhibitor's expense. Dates and times listed above are subject to change and will be specifically confirmed at a later date.
13. **LIABILITY** - Exhibitor assumes responsibility and agrees to indemnify and defend the Medicaid Congress, the Omni Shoreham hotel, and their respective employees and agents against any claims or expenses arising out of the use of the exhibition premises. Neither the Medicaid Congress nor the Omni Shoreham Hotel maintain insurance covering the Exhibitor's property and it is the sole responsibility of the Exhibitor to obtain such insurance if desired.

If the exhibit hall is uninhabitable due to acts of God, during any part or whole of the exhibition, the Conference is not responsible and the exhibitor hereby waives any claim against the Conference for losses or damages which may arise in consequence of such inability to occupy assigned space.

Contact Information

COMPANY NAME _____
 COMPANY REPRESENTATIVE _____
 ADDRESS _____
 CITY STATE ZIP _____
 PHONE () FAX () _____
 E-MAIL _____
 BADGE INFORMATION 1. (ALL-ACCESS)
 (2 PER 8' X 10' 2. _____
 BOOTH - EACH 1. _____
 ADDITIONAL 2. _____
 EXHIBITOR IS 3. _____
 (\$150 EACH) 4. _____

Summit Sponsorships

SPONSORSHIP LEVEL:

- Diamond \$100,000
 As a Diamond Level Sponsor, please list our company as the sponsor for the _____
 (please select from one of the event or item sponsorship categories below, \$10,000 or less in value)
- Platinum \$75,000
 As a Platinum Level Sponsor, please list our company as the sponsor for the _____
 (please select from one of the event or item sponsorship categories below, \$8,000 or less in value)
- Gold \$50,000
 As a Gold Level Sponsor, please list our company as the sponsor for the _____
 (please select from one of the event or item sponsorship categories below, \$5,000 or less in value)
- Silver \$25,000
- Bronze \$12,500

Event Sponsorships

- Reception \$15,000
- Luncheon \$6,500
- Continental Breakfast \$4,500
- Refreshment Break \$3,500

Item Sponsorships

- Notepad Folio \$25,000
- Conference Bag \$10,000
- Binder \$5,000
- Pocket Schedule \$5,000
- Name Badge/Lanyards \$7,500
- Cyber Café \$5,000
- Calculators \$3,500*
- Coffee Mugs \$2,500*
- Gel Click Pens \$2,500*

* Sponsorship fee only. Production cost additional.

Exhibiting

If you would like to purchase an 8' x 10' display space at the National Medicaid Congress, the price is \$1,995. This price includes one exhibit space, up to 2 exhibitor badges including one all-access badge to attend the educational sessions, June 5-6, your company listing in the program guide, and a post conference attendee list for a one-time mailing.

Yes, I would like to purchase an exhibit space at the Medicaid Congress for \$1,995 and would like to select:
 Booth # _____ 2nd Choice _____ 3rd Choice _____.

Yes, I would like the exhibit space at the Medicaid Congress that is included with my Grantorship level.
 Booth # _____ 2nd Choice _____ 3rd Choice _____.

Please list any companies you would rather not be near:

Payment Information

- Check enclosed for the amount of \$ _____
 (Please make check payable to Health Care Conference Administrators)
- Charge to credit card below for the amount of \$ _____
- AMEX Visa MC Exp. Date ____ / ____

ACCOUNT NUMBER: _____

NAME OF CARD HOLDER: _____

CARD HOLDER SIGNATURE: _____

100% payment is required for all marketing options chosen. Full payment must be received by 5/8/06. Cancellation fee for exhibit space is the full deposit. Exhibit and Sponsorship status is not final until payment is received. All fees are non-refundable. Tax ID Number: 91-1892021

A confirmation letter and exhibitor service kit will be sent to confirmed exhibitors prior to the conference.

Signature: _____ Date: ____ / ____ / ____

By signature above, the individual signing this contract represents and warrants that he/she is duly authorized to execute this binding contract, which includes the rules and regulations above.

MAKE CHECK PAYABLE TO:

Health Care Conference Administrators
 Please submit this form for registration by any of the following:
 Fax: 215-545-8107
 Email: joni.lipson@rmpinc.com
 Mail: Joni Lipson
 National Medicaid Congress
 100 North 20th Street, 4th Floor
 Philadelphia, PA 19103

Hotel Accommodations

See conference brochure for special rates.
 For reservations please call 800-545-8700 or 202-234-0700.

SAVE THESE DATES IN 2006!

Third Annual Connecting Communities for Better Health Learning Forum and Exhibition

April 9 - 11, 2006 • Washington, DC • www.ccbh.ehealthinitiative.org

Twelfth National HIPAA Summit

Collocated with the Third Annual CCHL Forum

April 9 - 11, 2006 • Washington, DC • www.HIPAAsummit.com

The Disease Management Colloquium

May 10 - 12, 2006 • Philadelphia, PA • www.DMConferences.com

The Quality Colloquium

August 20 - 23, 2006 • Harvard University Campus, Cambridge, MA • www.QualityColloquium.com

FDA Regulatory and Compliance Symposium

August 23 - 25, 2006 • Harvard University Campus, Cambridge, MA • www.FDASymposium.com

National Consumer Driven Healthcare Summit

September 13 - 15, 2006 • Washington, DC • www.ConsumerDrivenSummit.com

Third HIT Summit Collocated with the Thirteenth HIPAA Summit

September 25 - 27, 2006 • Washington, DC • www.HITSummit.com

Thirteenth HIPAA Summit Collocated with the Third HIT Summit

September 25 - 27, 2006 • Washington, DC • www.HIPAAsummit.com

Third National Medicare Prescription Drug Congress

October 15 - 17 2006 • Washington, DC • www.MedicareCongress.com

Seventh Annual Pharmaceutical Regulatory and Compliance Congress

November 8 - 10, 2006 • Washington, DC • www.PharmaCongress.com

Contact for Exhibiting, Sponsorships and Advertising:

Joni Lipson at 800-546-3750 • direct line: 215-599-6626 • joni.lipson@rmpinc.com